



411 West Congress St., Maple Lake, MN 55358 Toll Free 877-466-8837 www.wavearmor.net

ASSEMBLY INSTRUCTIONS FOR 6 FOOT DOCK BENCH

PARTS LIST:

| ITEM | DESCRIPTION | QTY |
|------|-------------------------|-----|
| 1 | Bench seat | 1 |
| 2 | Bench back | 1 |
| 3 | Right hand arm | 1 |
| 4 | 3/8 hex bolt X 1.50 lg | 12 |
| 5 | 3/8 flat washer | 12 |
| 6 | Left hand arm | 1 |
| 7 | 5/16 hex bolt x 1.00 lg | 4 |
| 8 | 5/16 lock washer | 4 |
| 9 | Brace for bench | 1 |

Assembly Instructions:

1. Put bench seat (item 1) into groove on right arm (item 3). Figure A
2. Align holes on arm (item 3) with inserts on seat (item 1). Figure A
3. Put flat washer (item 5) on hex bolt (item 4). Figure A
4. Screw hex bolt (item 4) with washer (item 5) thru arm (item 3) into bench (item 1) making sure to leave loose. (2 places) Figure A
5. Put bolt (item 5) and washer (item 4) thru arm (item 3) and into bench (item 1) on bottom of assembly making sure to leave loose. (2 places) Figure B
6. Put seat back (item 2) into groove on arms (item 3). Figure A
7. Align holes in arm (item 3) and inserts in bench back (item 2). Figure A
8. Put bolt (item 4) and washer (item 5) thru holes in arm (item 3) and screw into inserts on bench back (item 2). (2 places) Figure A
9. Repeat steps 1 to 8 for left arm (item 6).

FIGURE A

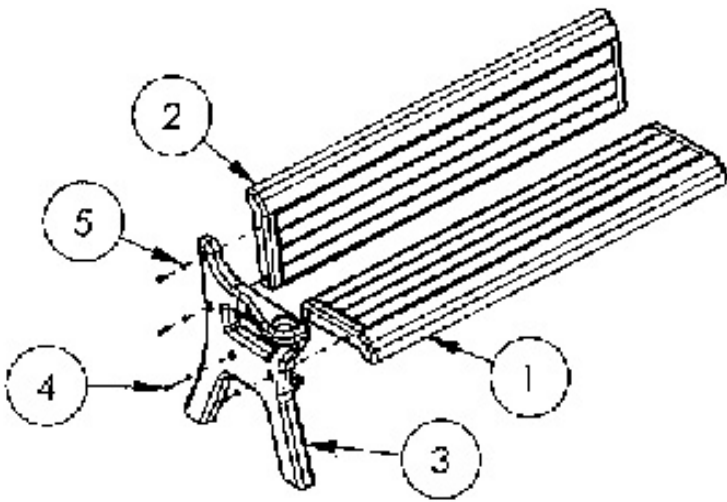

FIGURE B

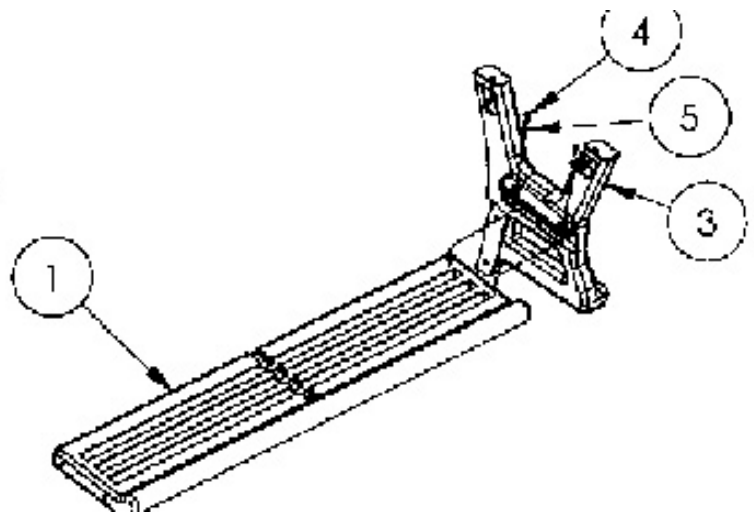

Figure A

Figure B

10. Put brace on in center of bench in grooves provided. Figure C
11. Align holes and inserts. Figure C
12. Put lock washer on bolt and tighten into insert till snug. (**caution do not over tighten these bolts**) Figure C
13. Repeat bolting process in 4 places. Figure C

FIGURE C

